

# Flip Up Tub Seats

## Phenolic

Configuration:

**70 Series**  
Phenolic

### Application Use:

Architectural

Commercial

Institutional

Residential

### Specifications

The folding tub seat is manufactured from 1" (25mm) diameter, 18 gauge type 304 stainless steel tubing with #4 satin finish. Hinged mounting brackets shall be 12 gauge type 304 stainless steel. Hooks firmly into place when in the up position to be stored safely out of the way. Solid Phenolic seat shall be 1/2" (13mm) thick and shall be fire and mildew resistant. Seat unit shall comply with all applicable federal, provincial and local building safety codes.

Woodgrain shown, also available in White.



15" x 28" (381mm x 711mm)	White	Model # 70-PH152801
15" x 28" (381mm x 711mm)	Woodgrain	Model # 70-PH152815
15" x 32" (381mm x 812mm)	White	Model # 70-PH153201
15" x 32" (381mm x 812mm)	Woodgrain	Model # 70-PH153215

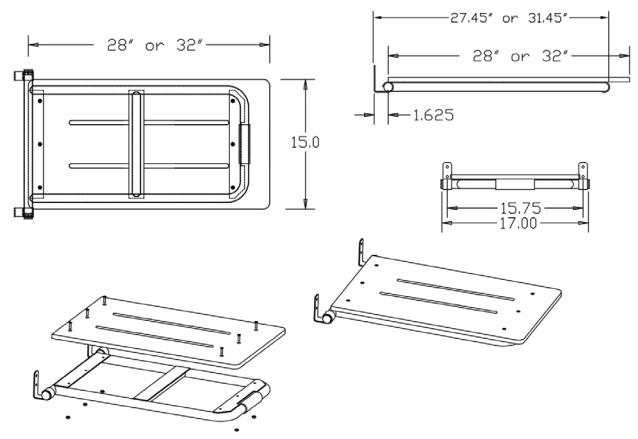

Folding Shower Seats have been designed and tested to withstand 250lbs. (114kgs) of load when properly installed.\* This exceeds HUD, FHA, VA, ADA, ANSI and other federal, provincial and local codes. \*Shower seats can only be as strong as what they are mounted to. It is imperative when installing any shower seat to consult with a qualified contractor to insure you have sufficient backing.