



AMERICAN SPECIALTIES, INC.

MODEL No: 0032

ISSUED: 1-87

REVISED: 9-04

PARTITION MOUNTED DUAL TOILET PAPER DISPENSER

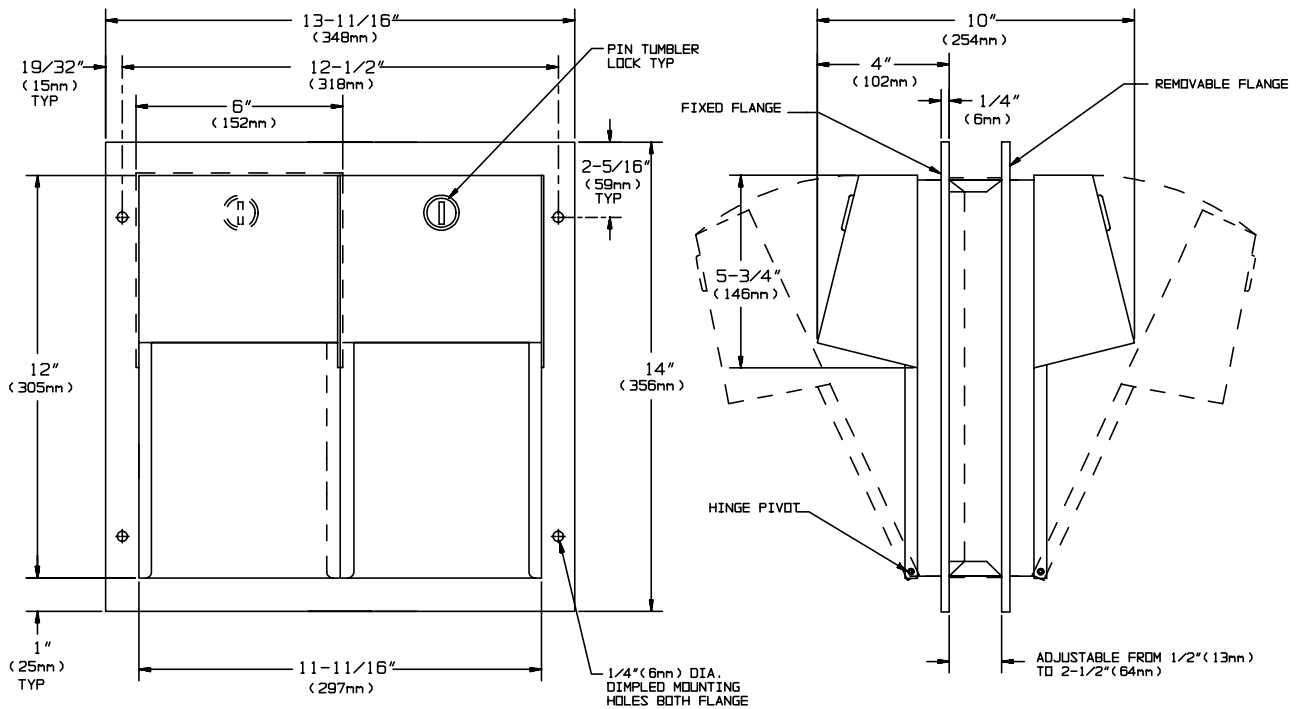

SPECIFICATION

Partition Mounted Dual Hide-A-Roll Toilet Tissue Dispenser shall hold and dispense four (4) standard or four (4) 5-1/4" dia. (133 mm) 1800 sheets tissue rolls and shall have doors, door frames, and dispensing mechanism guide tracks fabricated of alloy 18-8 stainless steel, type 304, 18 gauge; cabinet body shall be same grade, 22 gauge. All exposed surfaces shall be N^o4 satin finish and be protected during shipment with a PVC film easily removable after installation. Internal mechanism levers shall be fabricated of molded high-impact resistant plastic for smooth operation. Structural assembly of body and door components shall be of welded construction. Door hinges shall be of heavy-duty stainless steel 3/16" dia. rivets. Doors shall be held closed with tumbler locks keyed alike to other ASI washroom equipment. Vandal resistant rollers shall be of molded high impact resistant plastic with integral molded-in stainless steel end pins and four (4) rollers shall be supplied.

INSTALLATION

Unit is partition mounted using four (4) N^o10 self tapping screws (supplied) per side through mounting holes provided through fixed mounting frame and adjustable mounting frame. Mounting flanges adjust to accommodate partition thickness of 1/2" (13mm) minimum to 2-1/2" (64mm) maximum. For compliance with ADA Accessibility Guidelines, top of unit should be installed 29" (737mm) above finished floor.

Partition Cutout Required is...11-7/8" W x 12-1/4" H x 1/2" to 2-1/2" Part. Thick(304mm x 311mm x 13mm to 64mm)

OPERATION

Reloading instructions are printed on graphic label inside door. Bottom roll is depleted prior to top roll automatically dropping into lower position for use. Empty rollers can not be removed without key unlocking door. Individual two-roll dispenser is accessible from each side of partition.

Accessory Specialties

AMERICAN DISPENSER

Desert Ray Products

WATROUS INC.