

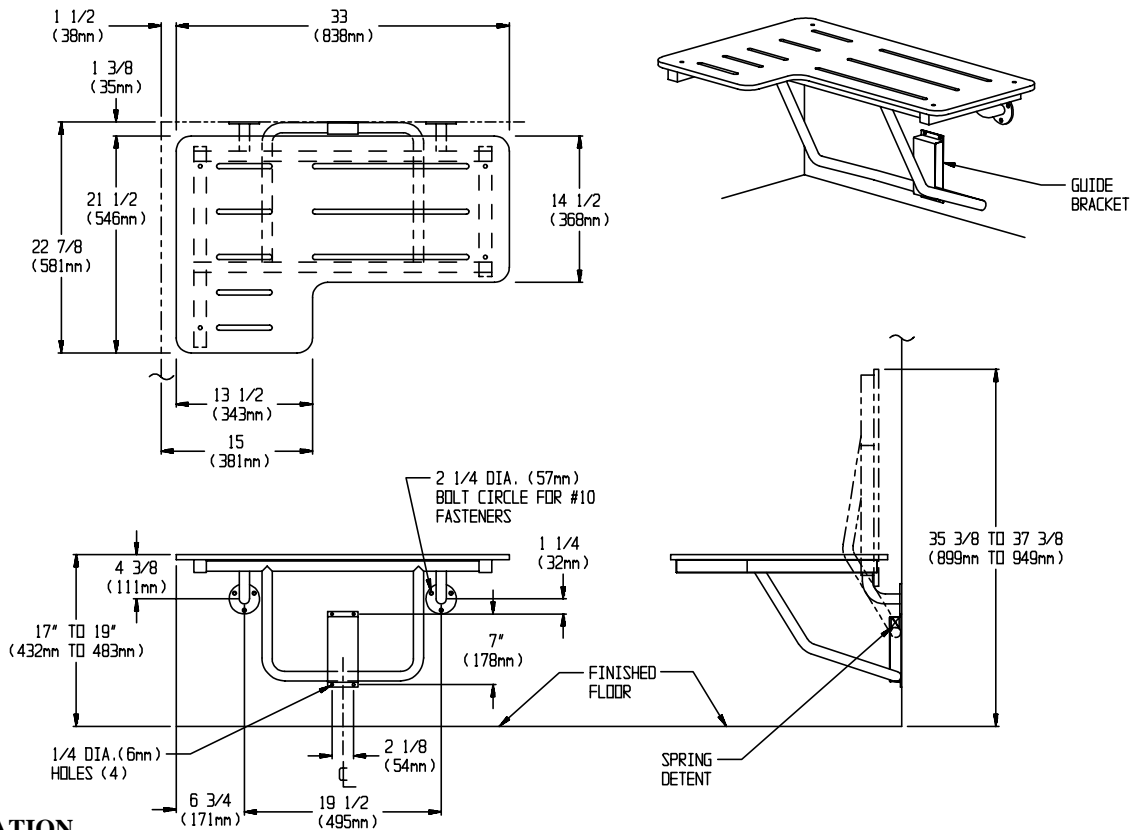

L-SHAPED PHENOLIC FOLD-UP SHOWER STALL SEAT (pg 1 of 2)



**SPECIFICATION**

“L-shaped” Phenolic Fold-up Shower Stall Seat shall have all metal parts fabricated of 18-8 alloy type 304 stainless steel. Seat frame and support legs shall be 1" (25mm) dia. and 1-1/4" (32mm) square x 18 gauge (1.2mm) with 3/16" (4.8mm) thick mounting flanges and 16 gauge (1.5mm) guide bracket/arm support. All exposed surfaces shall have N° 4 satin finish. Structural assembly shall be of welded construction and all exposed edges and corners shall be radiused and/or deburred. Seat shall be solid phenolic with ivory color top and bottom surfaces and shall have black edges. Support arm shall fold up when in retracted position to provide low profile against wall. No extra fittings shall be required to retain seat in storage position. Guide bracket shall control seat lowering into operating position. Unit shall satisfy ADA Accessibility Guidelines when mounted properly.

**INSTALLATION**

This unit is surface mounted. Installer/construction contractor must provide concealed anchor plate or blocking as specified in construction documents or as required by local building codes prior to wall finishing. Fasten unit flanges and guide bracket to concealed anchor or blocking plate with appropriate hardware. See “STRENGTH” section below. Note that concealed mounting plates or anchors and hardware are not supplied with this product and must be specified separately. Ensure that mounting configuration complies with local building codes. Unit is reversible in the field for right or left hand installation.

**STRENGTH**

ASI Shower Seats are designed to meet and exceed **ADAAG** requirements as published in ICC/ANSI A117.1-2003 section 610 and CFR 28 Part 36, Federal Register Vol. 56 N° 144, 26 July 1991, section 4.21.3 and section 4.26.3, that fabricated product shall be of adequate strength to support a load of 250 pounds (113.4 kg) and unit shall conform to size and edge clearances as diagrammed. Mounting to the wall is a critical part of the system to meet this requirement. To withstand the shear, tension or pullout, and torsion loads generated by the maximum loading, the fastener system must be adequately sized. Unit is load rated to support a weight of 500 lbs at front edge when properly installed and has been tested to successfully hold a weight in excess of 1000 lbs.



# AMERICAN SPECIALTIES, INC.

441 Saw Mill River Road, Yonkers, NY 10701 (914) 476-9000  
www.americanspecialties.com

MODEL No: 8206

ISSUED: 1-87

REVISED: 12-05

## L-SHAPED PHENOLIC FOLD-UP SHOWER STALL SEAT (pg 2 of 2)

### MATERIALS

**Tube:** 18 gauge (.048 in. <1.22mm> thick), type 304 stainless steel 1" (25mm) dia. and 1-1/4" (32mm) square. Unitized all welded construction. Exposed surfaces have satin finish. Edges and corners are radiused and burr free. Frame is field reversible for either left or right hand.

**Flange:** 3/16" (4.8mm), type 304 stainless steel. Exposed surfaces have satin finish. Edges are radiused and burr free.

**Bracket:** 16 gauge (.06 in. <1.52mm> thick), type 304 stainless steel. Exposed surfaces have satin finish. Edges and corners are radiused and burr free.

**Seat:** Solid Phenolic ("L" shape) 1/2" x 33" x 21-1/2"(13mm x 838mm x 546mm) nonporous seat has ivory colored top and bottom surfaces with semi-gloss finish and black edges with radiused and burr free corners. Seat top shall be field reversible for left or right hand. Seat top shall have slots for water drainage and user slip resistance. Mounting hardware is smooth stainless steel dome head carriage bolts with acorn nuts on bottom.

**Spring:** Stainless steel wire, type 304, 1" body dia. (25 mm) x 3" body length (76mm) x .075" diameter (1.91mm).

### OPERATION

Fold-up Shower Seat requires only one hand operation to manually lower to horizontal position for use or raise for departure and arrival. Guide bracket with spring detent prevents seat from dropping and provides positive support in usage position as well as spring locked storage position.